



VEGA 350-CP

The Value For Money Pouch Maker



VALUE FOR TRUST



VEGA 350-CP

The Value For Money Pouch Maker

Bang on target - every time, to serve demands of your customers for pre-formed pouches. Vega 350-CP is a servo driven pouch maker to convert laminates of PET Films from 30 to 80 microns into centre fin seal pouches. We also offer facility to make Lap Seal (face to back) Pouches from BOPP films. Three side seal can be added as an option to the machine, making it more versatile. It is the most value for money pouch maker in the world today.

Specifications:

Film Index	AC Brushless Servo Motor	
Polymer Processing Capability	Laminates of Polyester / CPP / BOPP	
Thickness of the Film (microns)	Maximum	Minimum
	80	30
Processing Data	Maximum	Minimum
Web Width (Lay-Flat Sheet width) (mm)	750	110
Draw Length (mm)	500	100 [#]
Off-wind Reel Diameter (mm)	500	
Maximum Speed (Mechanical)	Cycles / Minute**	
• Center Fin Seal / Lap Seal Pouches	165	
• Three Side Sealed Pouches (Optional)	120	
Electrical Power	AC, 3 Phase, 415 ± 6% Volt, 50 Hz	
Total Connected Load (kW)	10 (Basic Machine Only)	
Air Consumption at NTP (Liters / Minute)	600 (Basic Machine Only)	
Foot Print (L x W x H) (mm) Indicative only	5200 x 2000 x 2000 (Basic Machine - Center Seal only)	
Machine Weight	~ 1.5 MT	

* Maximum usable width of the machine may change with attachments

Lesser Draw length on demand after internal approval of processing capability of suggested films.

** Depending on Type, Size, Material & Thickness

Attachments:

- Wide Range of Unwinders
- Lap Seal Attachment
- Three-side Seal Attachment with :
 - Unwinder
 - Film Folding Device
 - Centre Slitter
 - Edge-Trimming
- Air Shafts and Safety Chucks
- Film Reel Exhaust Sensor
- Edge Guide
- Side Gusset
- Offset Fin / Lap Seal
- Round Hole Punch
- Hanger (Euro Hole) Punch
- Tear Slit Punch
- V-Notch Punch
- Perforation
- Pin Holes
- Customer's Special Requirement

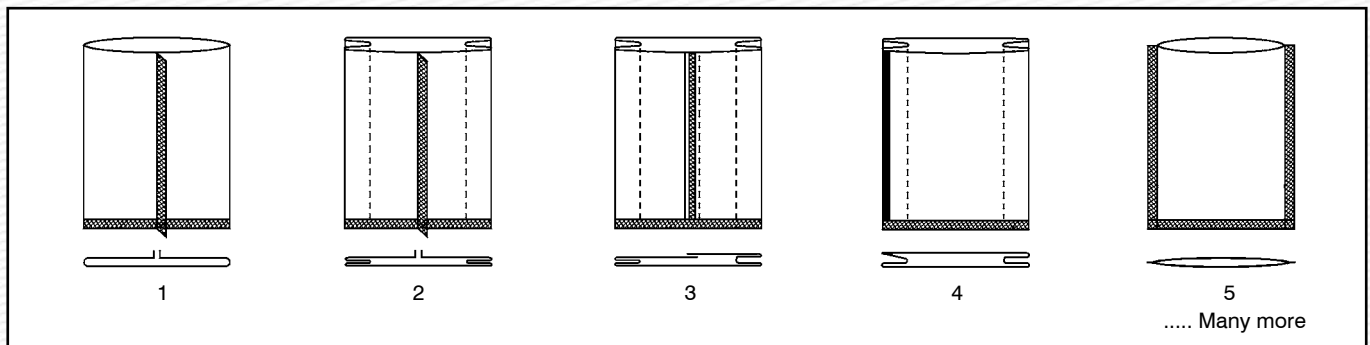

Photographs may show attachments or accessories, which may not be part of the standard scope of supply. The company reserves the right to modify, alter, change or substitute any feature & specifications which are subject to change without notice.

India Office & Works :



Survey No. 423/P, Sarkhej - Bavla Highway, Moraiya,
Tal.: Sanand, Dist.:Ahmedabad - 382 213, INDIA.
Phone: +91 2717 300700 • E-mail : sales@mamata.com
Website: www.mamata.com



USA Office :



2275, Cornell Ave., Montgomery, IL-60538, USA.
Phone : +1 630 801 2320 • Fax : +1 630 801 2322
E-mail : info@mamatausa.com
Website : www.mamatausa.com